

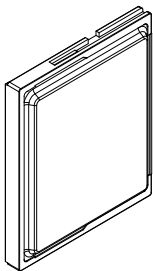

## Quantify Feature Card

Wi-Fi Squareline  
PN00-C100-01

### INSTALLATION GUIDE



### Product Description

The Feature Card securely connects qDevices to the local network and the Internet, enabling qDevices to communicate with each other. It also allows automated over-the-air software configuration, system reporting, updates and control. All Quantify Feature Cards are user-upgradeable to ensure extensibility, as well as accommodating possible future system requirements.

### Specifications

#### Wi-Fi

802.11 b/g/n

#### Wi-Fi Security

WPA2-Personal

#### Wi-Fi Frequency

2.4 GHz

#### Operating Temperature

0°C to 40°C

#### Operating Humidity

10 to 85% RH Non-condensing

#### Compliance

AS/NZS 4268:2012/Amdt 1:2013

#### Warranty

24-month product warranty

### Slide-in Feature Card Installation and Removal

**IMPORTANT:** Use only Quantify Technology Feature Cards, inserted with arrows in the correct alignment.

Fully insert the Feature Card into the slot on the Dimmer wall panel, as shown in the illustration. Align the arrow on the front of the Dimmer with the arrow on the Feature Card pull-tab to ensure the correct orientation.

To remove the Feature Card, pull firmly on the protruding tab.

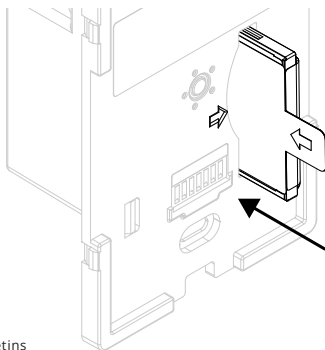

### Touch Panel Removal and Installation

**IMPORTANT:** Remove the Touch Panel using a soft plastic pry tool.

Insert the flat end of the tool between wall and the Touch Panel frame on the right hand side and carefully unclip the Panel from the Dimmer wall frame.

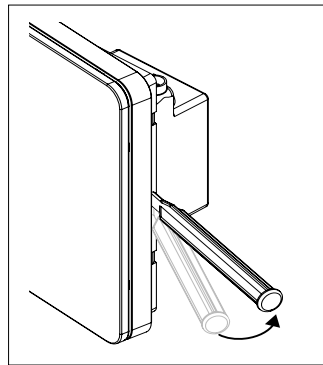

### Setup and Commissioning

**IMPORTANT:** The Feature Card needs to be commissioned with the qCommission App, available from the Apple App Store.



### Additional Help

**IMPORTANT:** We constantly work to improve our products, and document any changes or updates here:

[www.quantifytechnology.com/product-documentation/](http://www.quantifytechnology.com/product-documentation/)



## Warranty

### GENERAL WARRANTY ON PRODUCTS

#### LIMITED WARRANTY

Quantify offers a warranty of 24 months (Warranty Term) from the date of delivery of the Quantify products for all defects in materials or workmanship for any products supplied to the Client. Where a product supplied to the Client is defective within the Warranty Term, Quantify will either repair or replace those products at its discretion. Refurbished parts may be used to repair the Products. Replacement of the Product or a part does not extend or restart the Warranty Term. If a Product presented for repair is capable of retaining user-generated data, the Reseller acknowledges that repair of the Product may result in loss of the data.

Quantify may offer different delivery methods for warranty service, including, but not limited to, parts and product dispatches, mail-in service and onsite/in-home service or as otherwise agreed between the Client and Quantify in writing. Quantify will cover any costs to get the repaired/tested/replaced Products back to the Client. Any Products being sent in for warranty should be sent with all parts unless otherwise advised by one of Quantify's staff.

#### GENERAL EXCLUSIONS AND LIMITATIONS

The Warranty will not apply:

- a. to a Product which has not been installed, operated, maintained or used in accordance with the manufacturer's instructions or specifications provided with the Product;
- b. to a Product where the factory-applied serial number has been altered or removed;
- c. to a Product where the Product is, or has been damaged, has malfunctioned or failed due to alterations, accident, misuse, abuse, fire, liquid spillage, mis-adjustment of customer controls, used

on an incorrect voltage, power surges and dips, thunderstorm activity, acts of God, voltage supply problems, tampering or unauthorised repairs by any persons other than by Quantify, the operation of a computer virus of any kind, exposure to abnormally corrosive conditions or entry by any insect, vermin or foreign object in the Product, normal wear and tear, or use of parts and components not supplied or intended for use with Quantify's Products;

- d. to third-party products or software that are bundled or provided with the Services; and
- e. in relation to results to be obtained from the products or Software.

Full terms and conditions including Warranty Terms can be found on Quantify's website.

Technical Specifications for products with future release dates are subject to change and should not be relied upon.

#### Quantify Technology Pty Ltd

Suites 2 & 3, 6 Brodie Hall Drive, Technology Park,  
Bentley, WA, 6102

+61 (8) 6254 0200

info@quantifytechnology.com

**www.quantifytechnology.com**